

REVISEMENTS		DATE	APPROVED
F	REV PER EC 0130-0083-96	10-28-96	JH RS
G	REV PER EC 0118-0228-98	3-4-99	JH RS

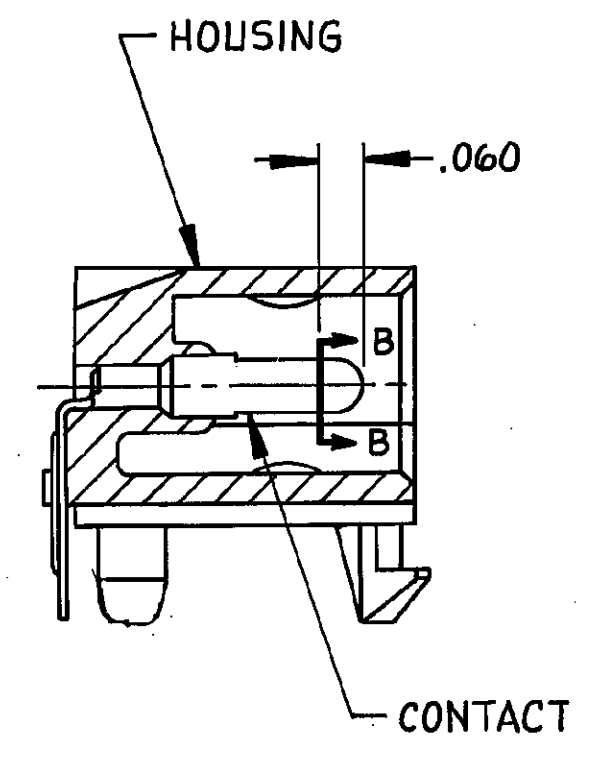

SECTION A-A

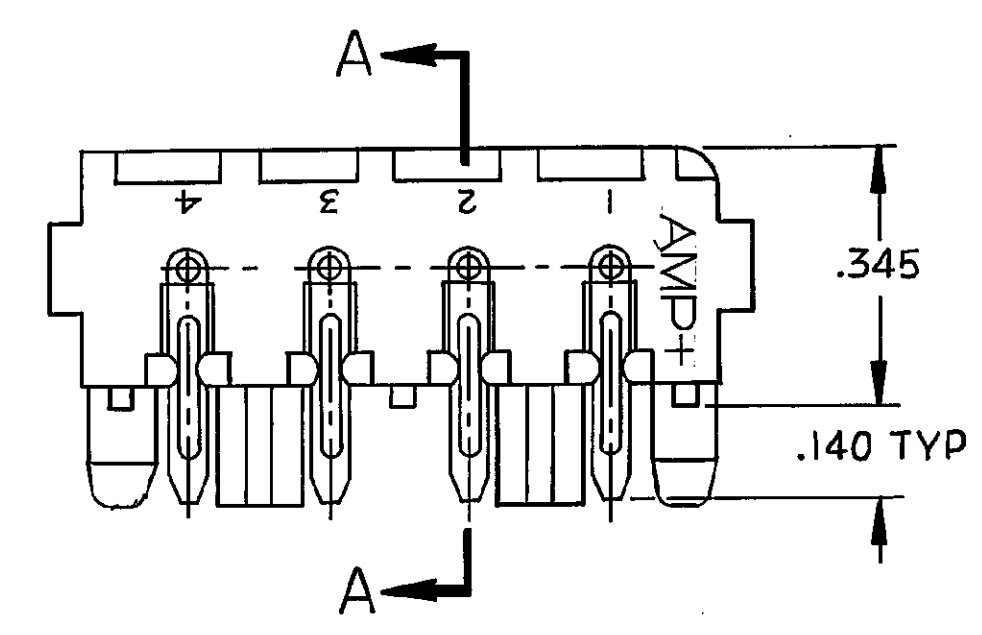
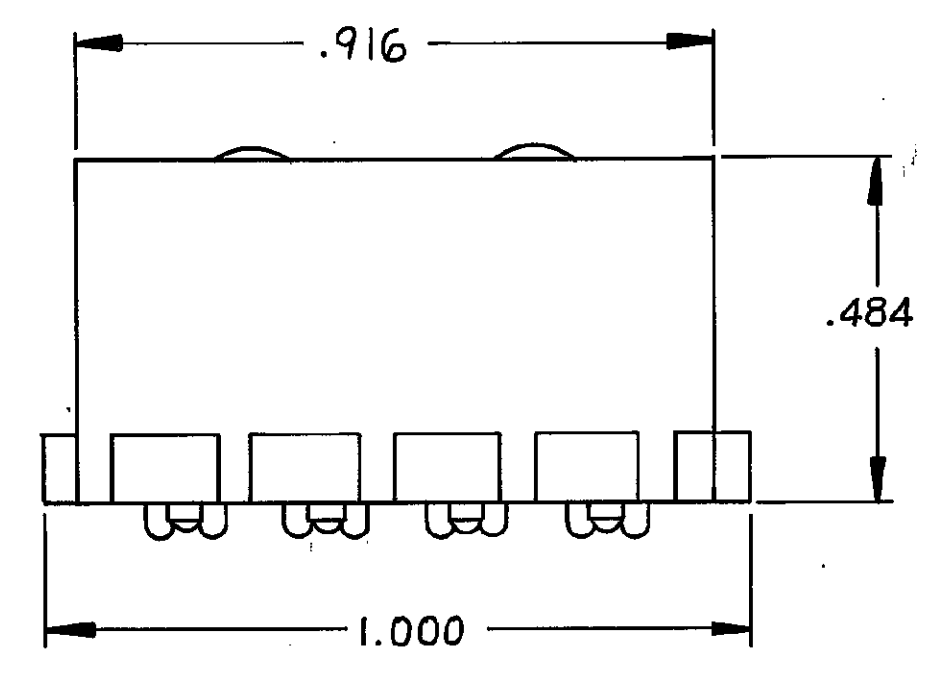
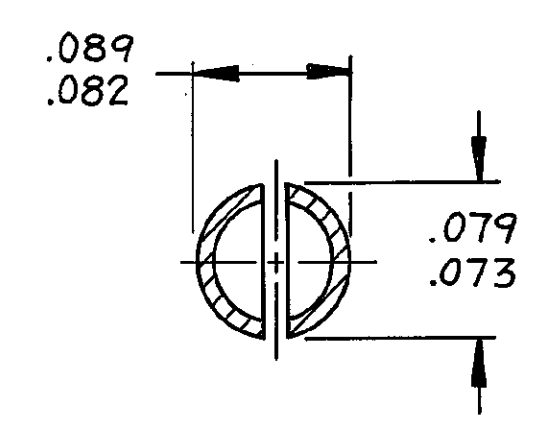
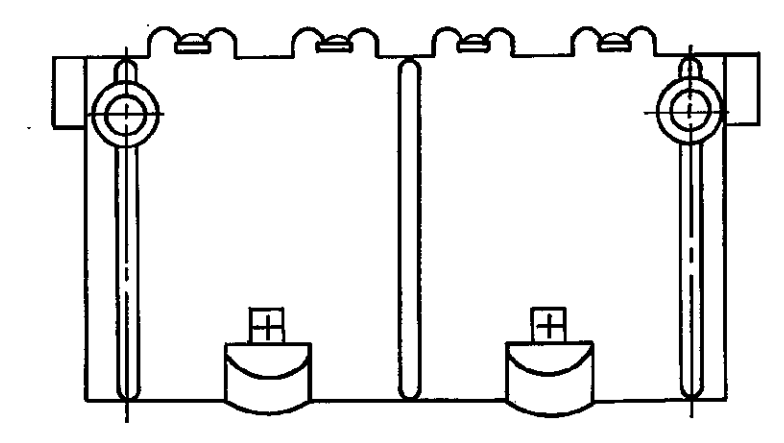

SECTION B-B
SCALE 10:1

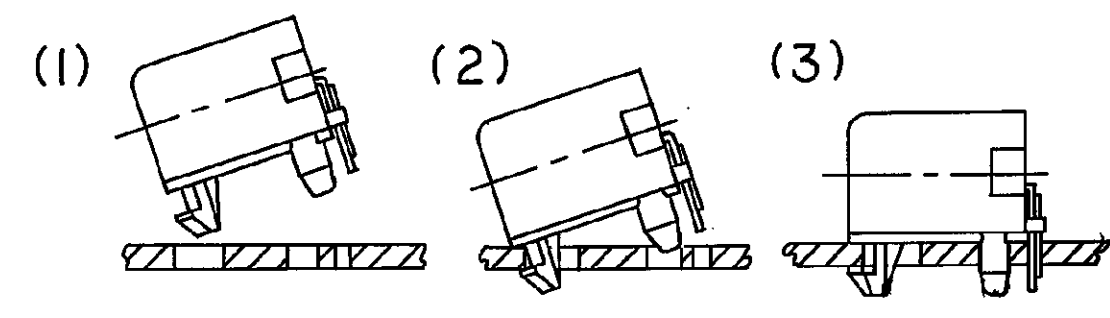

MOUNTING PROCEDURE

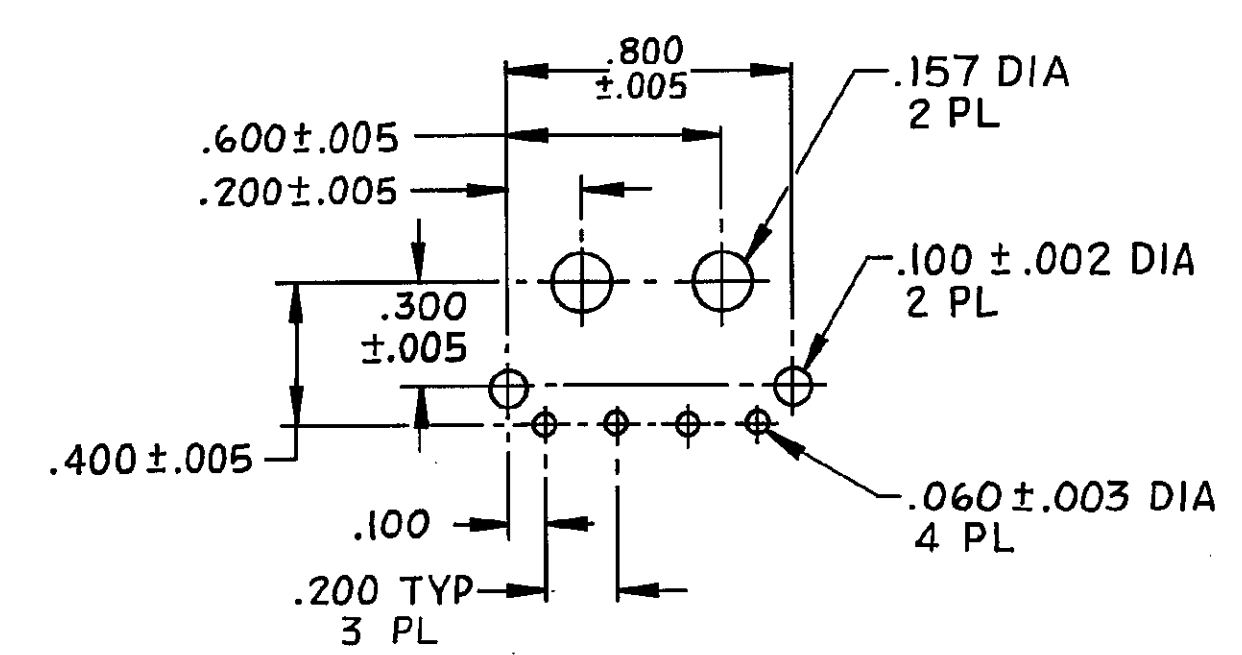

RECOMMENDED LAYOUT
FOR .062 THK P.C. BOARD
SCALE 2-1

- PARTS COMPLY WITH AMP SOLDERABILITY SPEC 109-11-3.
 - RECOMMENDED EXPOSURE TO SOLDER WAVE (490°F) NOT TO EXCEED 5 SECONDS.
- ⚠ MATERIAL - HOUSING: NYLON UL94V-2 (NATURAL). CONTACT: PHOS BRONZE (PRE-TIN).
 - ⚠ MATERIAL - HOUSING: NYLON UL94V-0 (WHITE). CONTACT: PHOS BRONZE (PRE-TIN).

UNLESS OTHERWISE SPECIFIED DIMENSIONS ARE IN INCHES. TOLERANCES ON: DECIMALS ± .015 ANGLES ± .015		CONTRACT NO. DR <i>H. Blanton</i> 6-27-84 CHK <i>M. Jones</i> 6-29-84 APPD <i>R. Glaser</i> 6-29-84		AMP INCORPORATED Harrisburg, Pa. 17105	
MATERIAL SEE TABLE		FINISH SEE TABLE		NAME P.C. HEADER, RIGHT ANGLE MOUNT, COMMERCIAL MATE-N-LOK, 4 CKT	
FINISH SEE TABLE		SIZE D	FSCM NO. 00779	DRAWING NO. 641737	
		SCALE 4-1		SHEET	