

Product manual

Vandal-proof MSM DP switch

CONTENTS

CONTENTS	1
1 PRODUCT DESCRIPTION	3
2 TECHNICAL DATA AND DIMENSIONAL DRAWINGS	3
2.1 Technical Data	3
2.2 Component dimensions	6
2.2.1 Component dimensions MSM 19 DP	6
2.2.2 Component dimensions MSM 22 DP	7
2.2.3 Component dimensions MSM 30 DP	8
2.3 Actuator Tolerance Range	9
2.4 Hole dimensions.....	10
2.5 Starting Torque.....	11
2.6 Switching Symbols.....	11
2.7 Accessories.....	11
3 ORDER NUMBERS	12
3.1 Order numbers MSM with micro switches of protection class IP40 (double-pole)	12
3.2 Lettering.....	13
4 ASSEMBLY	15
4.1 Installation	15
5 PACKAGING	16

Changes that contribute to technical improvement are subject to alternations							
Seite	Erstelldatum:	Ersteller:	Änderungsdatum:	Geändert von:	Änderungs-Nr.	Datenblatt Nr.	Index
1 of 18	07.03.2008	Schillak	07.12.2010	Schillak	10321	105.9534	d

6 QUALIFICATION TEST 17

6.1 IP Protection Class17

6.2 IK Protection Class17

6.3 ESD Protection.....17

6.4 Salt Spray Test.....17

7 APPROVALS 18

8 COMPLIANTS..... 18

Changes that contribute to technical improvement are subject to alternations

Seite	Erstelldatum:	Ersteller:	Änderungsdatum:	Geändert von:	Änderungs-Nr.	Datenblatt Nr.	Index
2 of 18	07.03.2008	Schillak	07.12.2010	Schillak	10321	105.9534	d

1 PRODUCT DESCRIPTION

- housing and actuator are made of high-quality stainless steel
- particularly suitable for the use in harsh environments
- the switch can be used in applications where an additional second contact is required for a safety circuit
- available with mounting diameters of 19, 22 and 30 mm
- equipped with two separated switching contacts which are available as normally open, normally closed or as change-over
- permissible switching voltages from 30 VDC to 250 VAC, switching currents from 0.1 to 10 Ampere
- equipped with flat-pin plugs to permit fast connection
- point and ring-illuminated versions for applications at night or as an optical status display

2 TECHNICAL DATA AND DIMENSIONAL DRAWINGS

2.1 Technical Data

Micro Switch for Electrical Rating (Protection Class IP 40)		0.1 A 30 VDC	5 A 125 VAC	3 A 250 VAC	10 A 250 VAC
Electrical Data					
Contact Material		gold	silver		silver
Switching Voltage max.	(VAC) (VDC)	30	125 / 250		250
Switching Current max.	(A)	0.1	5 / 3		10
Rated Braking Capacity	(W)	3	1250		2500
Lifetime ¹⁾ (at Rated Braking Capacity)		200,000	200,000		50,000
Lifetime (160mA at 48VDC)			1,500,000		
Initial Contact Resistance, new	(mΩ)	< 50	< 30		< 30
Insulation Resistance (IEC 512-2)	(MΩ)	> 100	> 100		> 100
Contact Bounce Time	(ms)	< 5	< 5		< 5

1) The electrical lifetime according to ENEC or UL approbation can vary, depending on the corresponding micro switch, under the lifetime indicated above. The type and license numbers for the individual micro switches can be found in "point 6 approvals".

Micro Switch for Electrical Rating (Protection Class IP 67)	0.1 A 250 VAC	5 A 250 VAC	10 A 250 VAC
Electrical Data			
Switching Voltage max. (VAC)	250	250	250
Switching Current max. (A)	0.1	5	10
Rated Braking Capacity (W)	25	1500	2500
Lifetime ¹⁾ (at Rated Braking Capacity)	50,000	50,000	10,000

➤ *Itally written types on request*

1) *The electrical lifetime according to ENEC or UL approbation can vary, depending on the corresponding micro switch, under the lifetime indicated above. The type and license numbers for the individual micro switches can be found in "point 6 approvals".*

Mechanical Data		
Actuating Force (N)		5.0
Actuating Travel Mounting Diameter 19, 22 mm (mm)		1.0
Actuating Travel Mounting Diameter 30 mm (mm)		1.2
Lifetime (Actuations)		1,500,000
Shock Resistance DIN EN 50102 (IK)		07
Climatical Data		
Operating/Storage Temperature (°C)		- 25 to + 85
Degree of Protection Front Side mechanical* (IP)		40
Degree of Protection Front Side Contact Area (IP)		67
Degree of Protection Rear Side Contact Area (IP)		40 / 67

Ring Illumination		
Supply Voltage Ring Illumination (VDC)		24

➤ *Supply Voltage 5 V and 12 V are available. Other supply voltages on request*

**The degree of protection refers to the area of the movable actuator.*

Changes that contribute to technical improvement are subject to alternations							
Seite	Erstelldatum:	Ersteller:	Änderungsdatum:	Geändert von:	Änderungs-Nr.	Datenblatt Nr.	Index
4 of 18	07.03.2008	Schillak	07.12.2010	Schillak	10321	105.9534	d

Point Illumination	Attention: Parts are delivered without series resistor.
Characteristics red LED Point Illumination	Forward Current max. 40 mA Forward Voltage at 10 mA = 2.0 VDC Forward Voltage max. = 2.5 VDC
Characteristics green LED Point Illumination	Forward Current max. 40 mA Forward Voltage at 10 mA = 2.0 VDC Forward Voltage max. = 2.5 VDC
Characteristics blue LED Point Illumination	Forward Current max. 20 mA Forward Voltage at 10 mA = 3.2 VDC Forward Voltage max. = 3.7 VDC

Recommendation of series resistors for Point Illumination:

LED-Color	I _D [mA]	I _{DMax} [mA]	U _V 5				U _V 12				U _V 24			
			R _V [Ω]	R _V ^{E24} [Ω]	P _V [W]**		R _V [Ω]	R _V ^{E24} [Ω]	P _V [W]**		R _V [Ω]	R _V ^{E24} [Ω]	P _V [W]	
red	10	---	300	300	0,03	1000	1000	0,10		2200	2200	0,22		
	---	40	63	62	0,10	238	240	0,38		538	240	0,86		
green	10	---	300	300	0,03	1000	1000	0,10		2200	2200	0,22		
	---	40	63	62	0,10	238	240	0,38		538	560	0,86		
blue	10	---	180	180	0,02	880	910	0,09		2080	2000	0,21		
	---	20	65	68	0,03	415	430	0,17		1015	1000	0,41		

- I_D LED-Forward Current [10mA]
- I_{DMax} LED-Forward Current max. [40mA/20mA]
- R_V Series Resistor (calculated)
- R_V^{E24} Series Resistor (regarding E24-Resistor series)
- P_V Power dissipation concerning R_V (calculated)

Material	
Component	Material
Housing	Stainless Steel
Actuator	Stainless Steel
Light Conductor (Point Illumination)	PC
Illuminated Ring (Ring Illumination)	PA
Gasket	NBR70
Switcher Collet	PA
Intermediate Connector non-illuminated	PA
Intermediate Connector illuminated	PA
Switcher Adapter	PA

2.2 Component dimensions

2.2.1 Component dimensions MSM 19 DP

MSM 19 DP ST

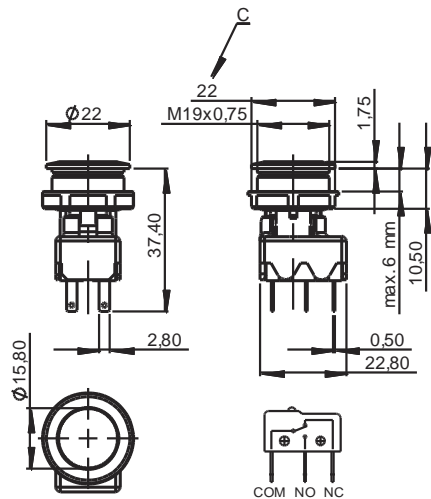

MSM 19 DP LE

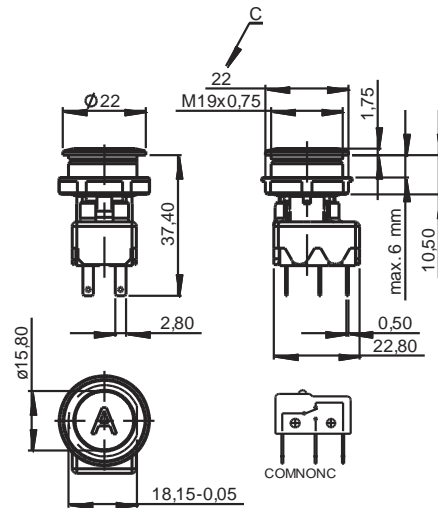

MSM 19 DP PI

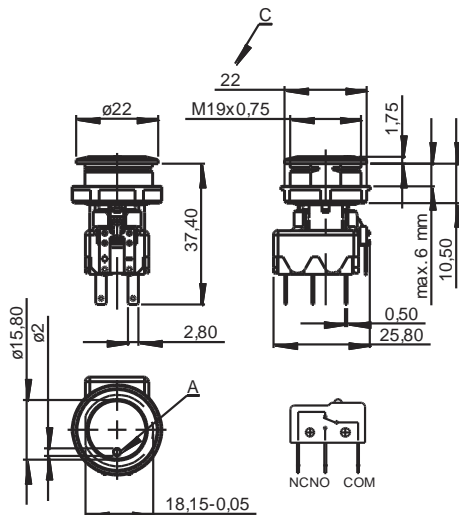

MSM 19 DP RI

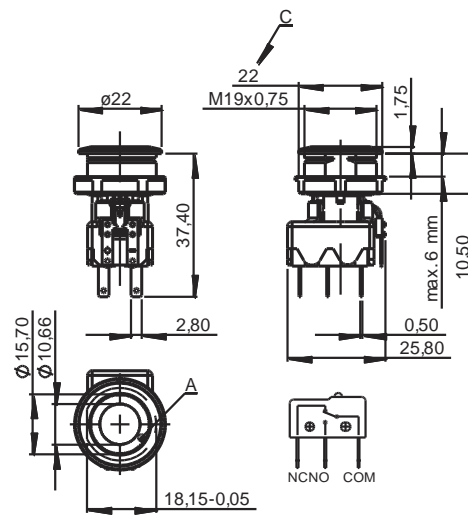

Legend

- A = Illumination Area
- B = Actuating Area
- C = Width Across Flats
- D = Knurled Nut

Changes that contribute to technical improvement are subject to alternations							
Seite	Erstelldatum:	Ersteller:	Änderungsdatum:	Geändert von:	Änderungs-Nr.	Datenblatt Nr.	Index
6 of 18	07.03.2008	Schillak	07.12.2010	Schillak	10321	105.9534	d

2.2.2 Component dimensions MSM 22 DP

MSM 22 DP ST

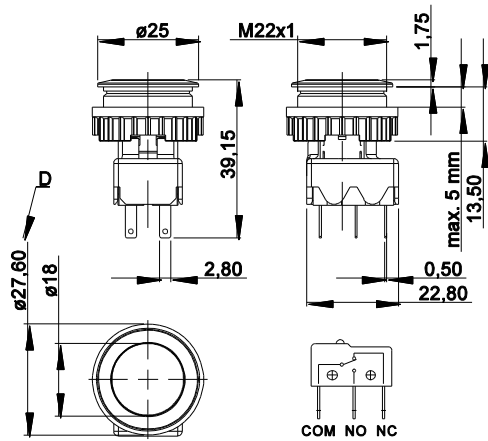

MSM 22 DP LE

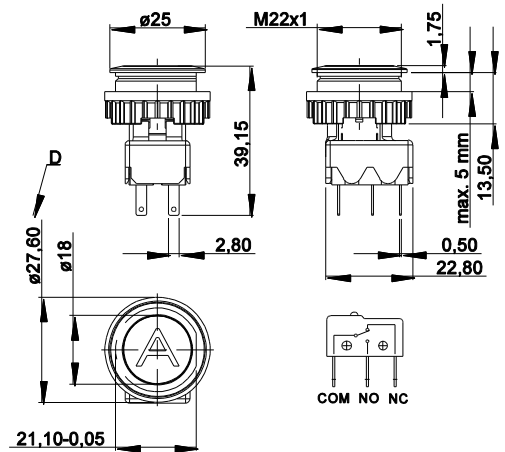

MSM 22 DP PI

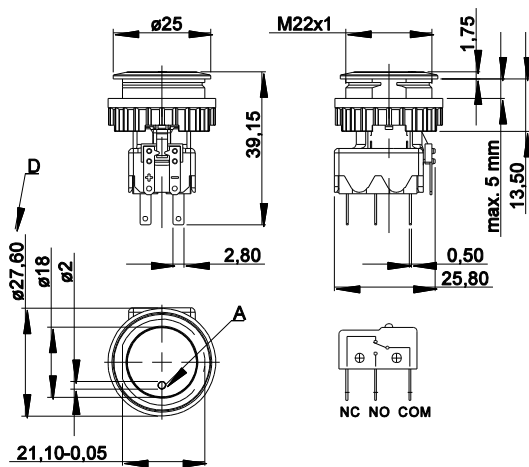

MSM 22 DP RI

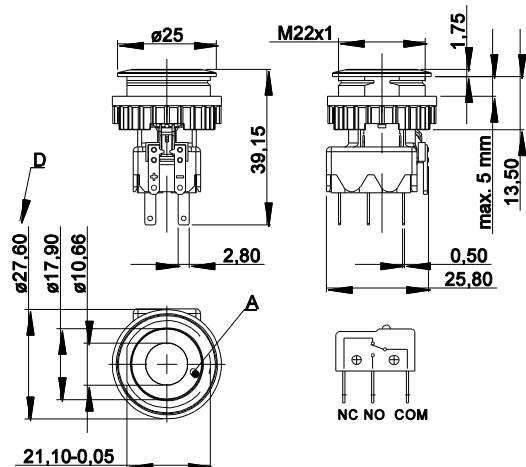

Legend

- A = Illumination Area
- B = Actuating Area
- C = Width Across Flats
- D = Knurled Nut

Changes that contribute to technical improvement are subject to alternations							
Seite	Erstelldatum:	Ersteller:	Änderungsdatum:	Geändert von:	Änderungs-Nr.	Datenblatt Nr.	Index
7 of 18	07.03.2008	Schillak	07.12.2010	Schillak	10321	105.9534	d

2.2.3 Component dimensions MSM 30 DP

MSM 30 DP ST

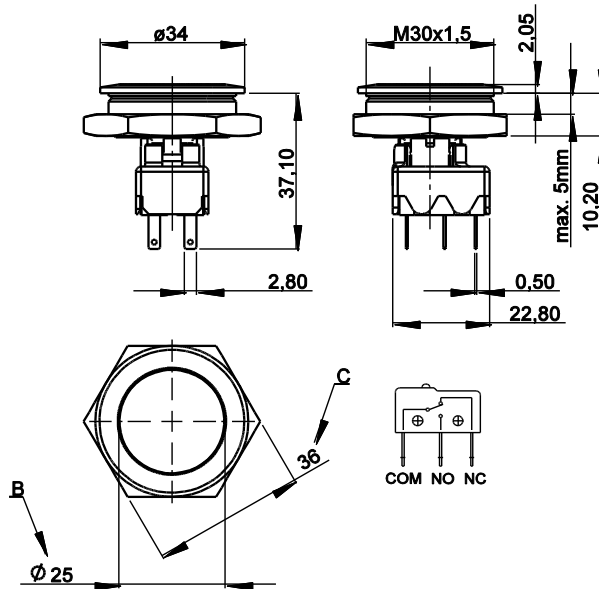

MSM 30 DP LE

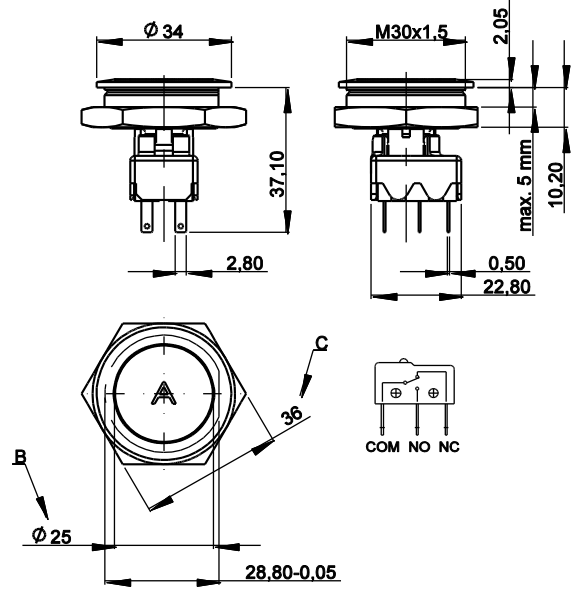

MSM 30 DP PI

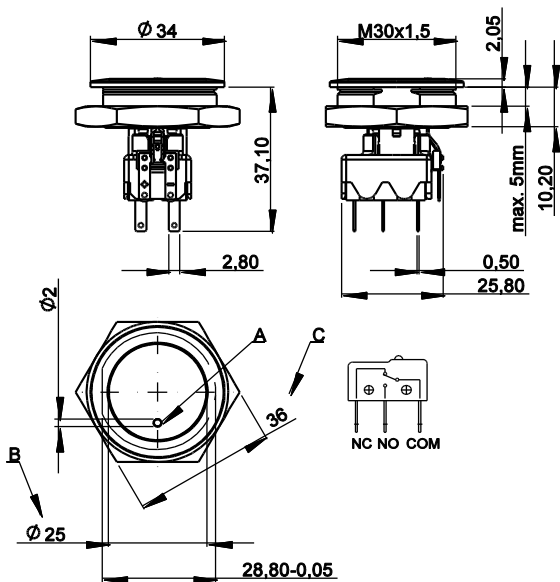

MSM 30 DP RI

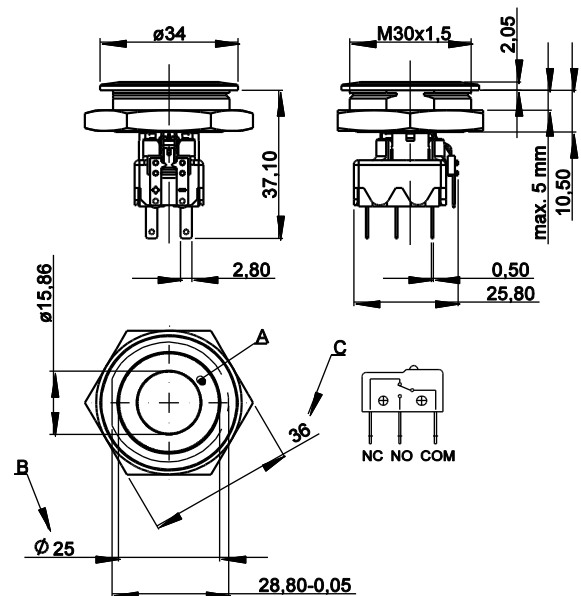

Legend

- A = Illumination Area
- B = Actuating Area
- C = Width Across Flats
- D = Knurled Nut

Changes that contribute to technical improvement are subject to alternations							
Seite	Erstelldatum:	Ersteller:	Änderungsdatum:	Geändert von:	Änderungs-Nr.	Datenblatt Nr.	Index
8 of 18	07.03.2008	Schillak	07.12.2010	Schillak	10321	105.9534	d

2.3 Actuator Tolerance Range

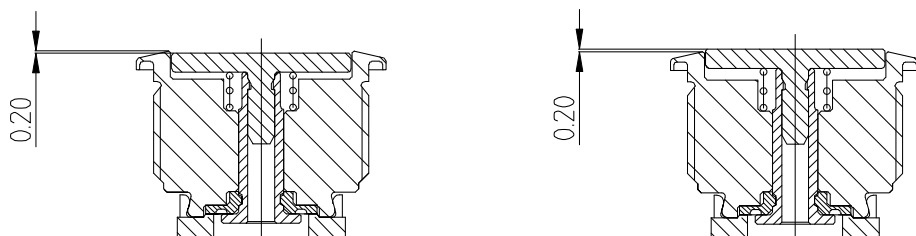

The mounting tolerance range of the actuator varies from 0.2 mm projection length and 0.2 mm short length to the housing edge. The slanting position of the actuator can range within this tolerance.

Changes that contribute to technical improvement are subject to alternations

Seite	Erstelldatum:	Ersteller:	Änderungsdatum:	Geändert von:	Änderungs-Nr.	Datenblatt Nr.	Index
9 of 18	07.03.2008	Schillak	07.12.2010	Schillak	10321	105.9534	d

2.4 Hole dimensions

MSM 19 ST / MSM 19 RI

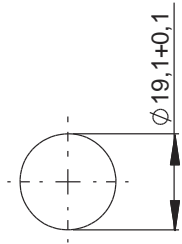

MSM 19 LE / MSM 19 PI / MSM 19 RI optional

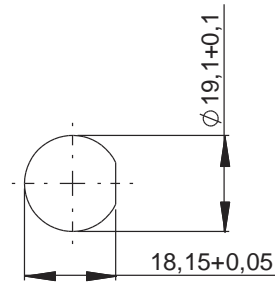

MSM 22 ST / MSM 22 RI

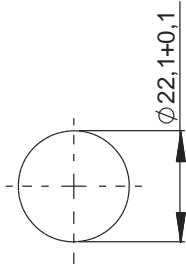

MSM 22 LE / MSM 22 PI / MSM 22 RI optional

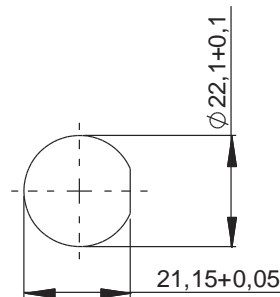

MSM 30 ST / MSM 30 RI

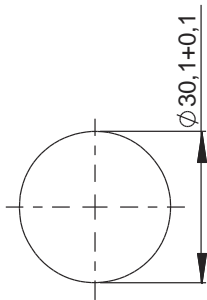

MSM 30 LE / MSM 30 PI / MSM 30 RI optional

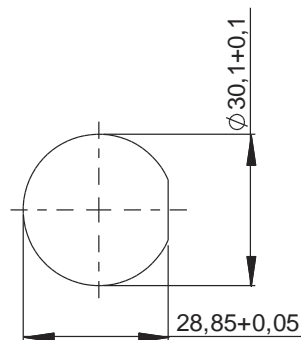

Changes that contribute to technical improvement are subject to alternations							
Seite	Erstelldatum:	Ersteller:	Änderungsdatum:	Geändert von:	Änderungs-Nr.	Datenblatt Nr.	Index
10 of 18	07.03.2008	Schillak	07.12.2010	Schillak	10321	105.9534	d

2.5 Starting Torque

	Plastic Nut max. (Nm)	Stainless Steel Nut * max. (Nm)
MSM 19	4.5	12
MSM 22	3.5	16
MSM 30	8	50

➤ * on request

2.6 Switching Symbols

MSM ST / MSM LE

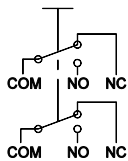

MSM PI

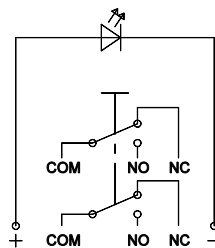

MSM RI

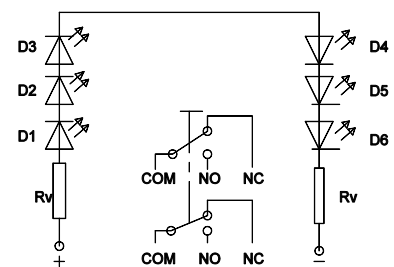

2.7 Accessories

MSM 22 Installation wrench

Order number: 1141.1337

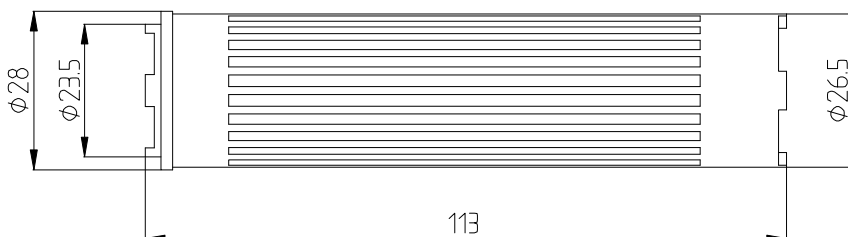

Changes that contribute to technical improvement are subject to alternations							
Seite	Erstelldatum:	Ersteller:	Änderungsdatum:	Geändert von:	Änderungs-Nr.	Datenblatt Nr.	Index
11 of 18	07.03.2008	Schillak	07.12.2010	Schillak	10321	105.9534	d

3 ORDER NUMBERS

3.1 Order numbers MSM with micro switches of protection class IP40 (double-pole)

Mounting Diameter (mm)	Ø 19	Ø 22	Ø 30
Electrical Rating max. 5 A / 125 VAC or 3 A / 250 VAC			
Standard	1241.6921.1120000	1241.6931.1120000	1241.6961.1120000
With Lettering	1241.6922.1120XXX	1241.6932.1120XXX	1241.6962.1120XXX
Point Illumination red	1241.6923.1121000	1241.6933.1121000	1241.6963.1121000
Point Illumination green	1241.6923.1122000	1241.6933.1122000	1241.6963.1122000
Point Illumination blue	1241.6923.1124000	1241.6933.1124000	<i>1241.6963.1124000</i>
Ring Illumination red	1241.6924.1121000	1241.6934.1121000	1241.6964.1121000
Ring Illumination green	1241.6924.1122000	1241.6934.1122000	1241.6964.1122000
Ring Illumination blue	1241.6924.1124000	1241.6934.1124000	<i>1241.6964.1124000</i>
Installation Wrench		1141.1337	

- *Italicly written types on request*
- *XXX for standard lettering see chapter [3.2 Lettering](#)*
- *At a minimum order quantity of 100 pieces the ring illuminated version with lettering is available on request.*

Additional switch types with the following electrical ratings are available on request:
0.1 A@30VDC, 10A@250VAC and also 5A@250VAC with IP67 protection class.
For these customized versions a minimum order quantity of 100 pieces has to be fulfilled.

For other types of the MSM product family, please visit:

http://www.schurter.de/wwwsc/con_pg70.asp?language_id=10

3.2 Lettering

The last three digits in the order number define the lettering.

000	No Lettering
001-074	Standard Lettering
101-	Customized Lettering

Example for ordering with lettering

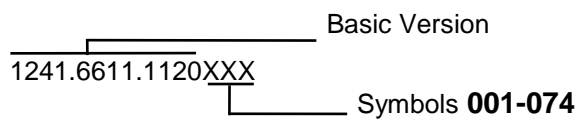

Ordering Indices for Lettering

001= A	016= P	031= 4	046= \updownarrow	061= EIN
002= B	017= Q	032= 5	047= \rightarrow	062= AUS
003= C	018= R	033= 6	048= \leftarrow	063= AUF
004= D	019= S	034= 7	049= \downarrow	064= AB
005= E	020= T	035= 8	050= \uparrow	065= ON
006= F	021= U	036= 9	051= %	066= OFF
007= G	022= V	037= +	052= $\sqrt{\quad}$	067= UP
008= H	023= W	038= -	053= CTRL	068= DOWN
009= I	024= X	039= .	054= RETURN	069= HIGH
010= J	025= Y	040= x	055= SHIFT	070= LOW
011= K	026= Z	041= ÷	056= LOCK	071= ON/OFF
012= L	027= 0	042= *	057= STOP	072= START
013= M	028= 1	043= =	058= ENTER	073= RESET
014= N	029= 2	044= #	059= BACK	074=
015= O	030= 3	045= ↔	060= LINE	

Lettering Size

MSM 19 LE / MSM 19 PI :

Single characters: height 8 mm, font: Helvetica normal DIN1451-1E
Text, max. 3 characters height 3 mm, font: Helvetica normal DIN1451-1E
Text, max. 6 characters: height 2.5 mm, font: Helvetica condensed DIN1451-3E
Symbols (indices 037-052): capitals height 8 mm, font: True Type, Symbol

MSM 22 LE / MSM 22 PI :

Single characters: height 8 mm, font: Helvetica normal DIN1451-1E
Text, max. 3 characters height 5 mm, font: Helvetica normal DIN1451-1E
Text, max. 6 characters: height 2.5 mm, font: Helvetica condensed DIN1451-3E
Symbols (indices 037-052): capitals height 8 mm, font: True Type, Symbol

MSM 30 LE / MSM 30 PI :

Single characters: height 12 mm, font: Helvetica normal DIN1451-1E
Text, max. 3 characters: height 7 mm, font: Helvetica normal DIN1451-1E
Text, max. 6 characters: height 3.5 mm, font: Helvetica condensed DIN1451-3E
Symbols (indices 037-052): capitals height 12 mm, font: True Type, Symbol

MSM 19 RI * / MSM 22 RI *:

Single characters: height 5 mm, font: Helvetica normal DIN1451-1E
Text, max. 3 characters height 3 mm, font: Helvetica normal DIN1451-1E
Symbols (indices 037-052): capitals height 5 mm, font: True Type, Symbol

MSM 30 RI *:

Single characters: height 8 mm, font: Helvetica normal DIN1451-1E
Text, max. 3 characters: height 3 mm, font: Helvetica normal DIN1451-1E
Text, max. 6 characters: height 2.5 mm, font: Helvetica condensed DIN1451-3E
Symbols (indices 037-052): capitals height 8 mm, font: True Type, Symbol

- ** At a minimum order quantity of 100 pieces the ring illuminated version with lettering is available on request.*

Changes that contribute to technical improvement are subject to alternations							
Seite	Erstelldatum:	Ersteller:	Änderungsdatum:	Geändert von:	Änderungs-Nr.	Datenblatt Nr.	Index
14 of 18	07.03.2008	Schillak	07.12.2010	Schillak	10321	105.9534	d

4 ASSEMBLY

4.1 Installation

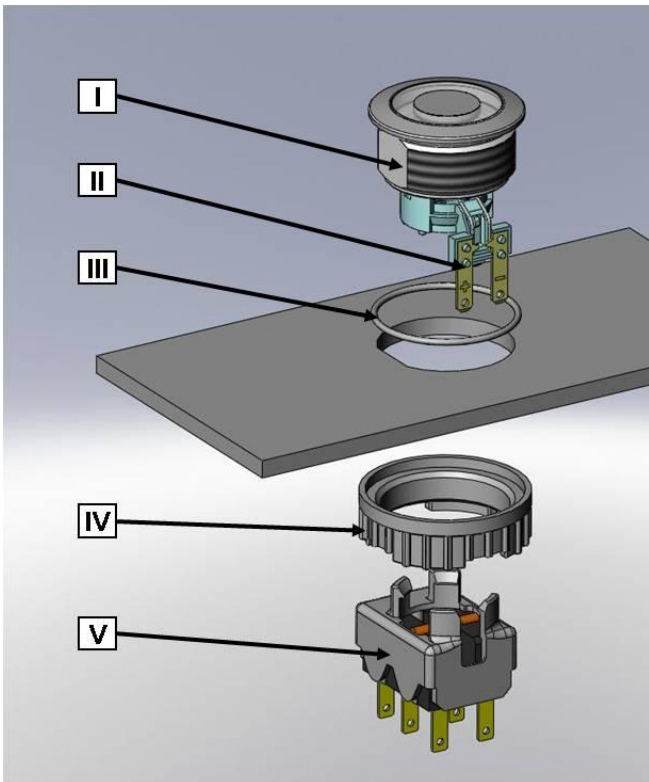

Installation instruction

1. Place the gasket accurately on the actuator housing. Then mount the actuator housing assembly into the panel.
2. Tighten the screw nut with the torque instructions according to [Chapter 2.5](#)
3. Clasp the micro switch assembly into the actuator housing.

Installation information:

1. The power supply and the configuration of the flat pin terminals has to be installed correctly for the illumination and micro switch function.
2. Insulate the terminals as required
3. Installation instructions according to VDE-standard DIN VDE 0100-100 or alternatively IEC 60354 standard

Legend

- I = Housing Assembly
- II = Flat Pin Terminals (illumination)
- III = Gasket
- IV = Screw Nut
- V = Micro Switch Assembly

Changes that contribute to technical improvement are subject to alternations

Seite	Erstelldatum:	Ersteller:	Änderungsdatum:	Geändert von:	Änderungs-Nr.	Datenblatt Nr.	Index
15 of 18	07.03.2008	Schillak	07.12.2010	Schillak	10321	105.9534	d

5 PACKAGING

MSM Switch

MSM 19		10 pieces per box with inlay
MSM 22		10 pieces per box with inlay
MSM 30	1 piece in air cushion bag	10 pieces per box

The nuts with gaskets and corresponding micro switches are packed separately and enclosed in the box.

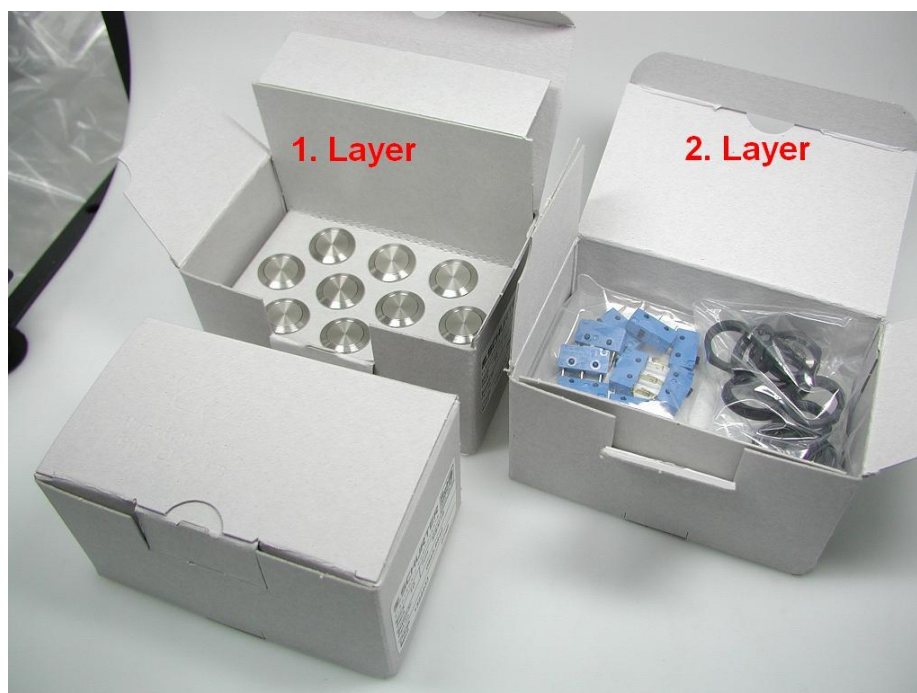

Changes that contribute to technical improvement are subject to alternations							
Seite	Erstelldatum:	Ersteller:	Änderungsdatum:	Geändert von:	Änderungs-Nr.	Datenblatt Nr.	Index
16 of 18	07.03.2008	Schillak	07.12.2010	Schillak	10321	105.9534	d

6 QUALIFICATION TEST

6.1 IP Protection Class

IP Protection Class IEC/DIN/EN/ 60529	IP 67
---------------------------------------	-------

6.2 IK Protection Class

Tested Centrally

IK Protection Class DIN EN 50102	IK 07
----------------------------------	-------

6.3 ESD Protection

ESD-Test according to DIN 61000-4-2:

4kV Contact Discharge	MSM DP ST Ø 19; 22; 30 mm
4kV Contact Discharge	MSM DP LE Ø 19; 22; 30 mm

6.4 Salt Spray Test

Salt spray test according to DIN 50021- SS
24h, 48h and 96h residence time

The surface of the stainless steel material is covered with a molecular-passive layer. Only under very unfavourable conditions it is possible, that iron and rust molecules as well as base metals penetrate the passive layer as foreign substances (pollutions) and initiate the rust process.

The smoothness of the actuator was not affected. After the residence time the tested samples were cleaned under running water and all rust spots could be removed.

Changes that contribute to technical improvement are subject to alternations							
Seite	Erstelldatum:	Ersteller:	Änderungsdatum:	Geändert von:	Änderungs-Nr.	Datenblatt Nr.	Index
17 of 18	07.03.2008	Schillak	07.12.2010	Schillak	10321	105.9534	d

7 APPROVALS

The listed approvals only refer to the micro switch and not to the complete switch.

Micro switch:

Type	Licence number	ENEC VDE / KEMA	UL 1054 CSA C22.2 NO55
1050.1151	097550	DIN EN 61058	E41791
1050.1102	097550	DIN EN 61058	E41791
1050.1103	097550	DIN EN 61058	E41791
SS-01 T	40008425	DIN EN 61058	E41515
SS-5 T	129246	DIN EN 61058	E41515
SS-10 T	125256	DIN EN 61058	E41515
DC3GL1AA	2089323.01	DIN EN 61058	E23301
DC1GL1AA	2089323.01	DIN EN 61058	E23301
DC2GL1AA	2089323.01	DIN EN 61058	E23301

8 COMPLIANTS

All articles are ROHS-compliant and in compliance to the Low Voltage Directive (2006/95/EC).



Changes that contribute to technical improvement are subject to alternations							
Seite	Erstelldatum:	Ersteller:	Änderungsdatum:	Geändert von:	Änderungs-Nr.	Datenblatt Nr.	Index
18 of 18	07.03.2008	Schillak	07.12.2010	Schillak	10321	105.9534	d