

## Mini-module with ATmega128 microcontroller

dip ATmega128

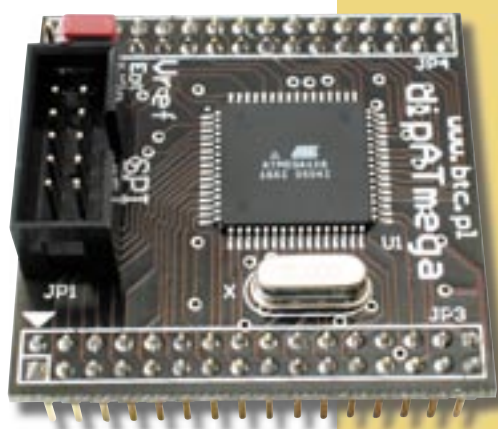

*ZL7AVR is an easy to use versatile mini-module based on Atmels ATmega128 microcontroller (AVR enhanced RISC architecture). In ZL7AVR module all ports and signals of the microcontroller are available on two-row pin connectors with 0,1' pitch (pin headers). In addition, we offer prototype board ZL8AVR.*



# Pin description

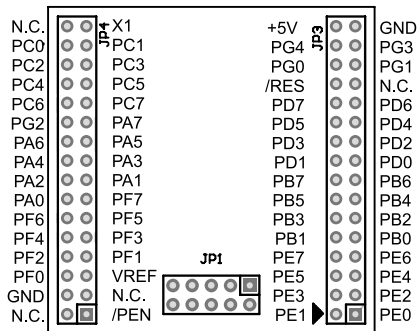

## JP1 – ISP connector

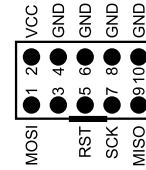

# Evaluation board

In order to developing projects with ZL7AVR more effectively, an evaluation board has been prepared. It includes the following elements:

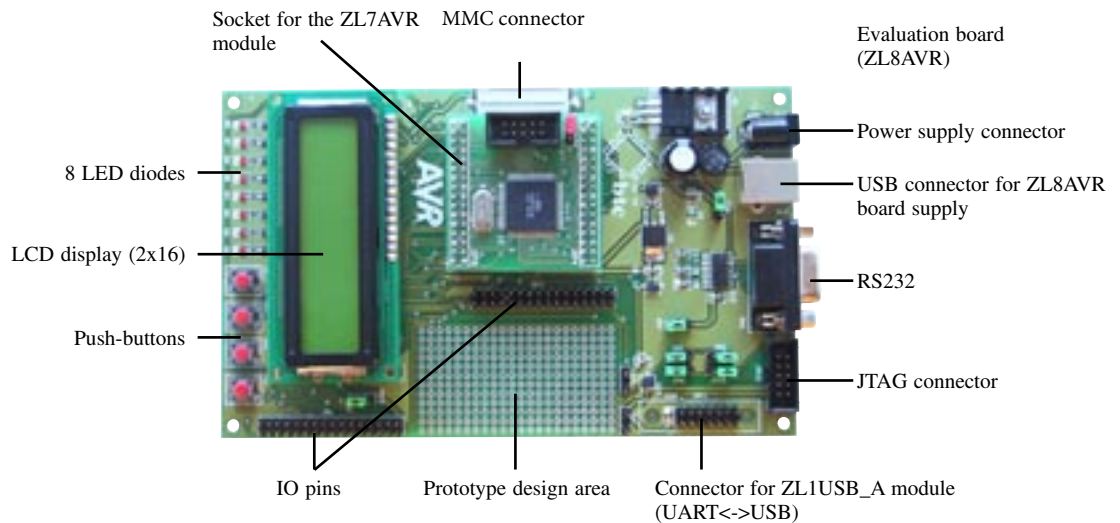

# Standard equipment

Ordering code	Description
ZL7AVR	▶ Mini-module assembled and tested.



**btc**  
 BTC Korporacja  
 03-237 Warsaw, Poland  
 ul. Inowlodzka 5  
 e-mail: office@kamami.com  
<http://www.kamami.com>

**Disclaimer**

BTC Korporacja makes no warranty for the use of its products and assumes no responsibility for any errors which may appear in this document nor does it make a commitment to update the information contained herein.

BTC Korporacja products are not intended for use in medical, life saving or life sustaining applications.

BTC Korporacja retains the right to make changes to these specifications at any time, without notice.

All product names referenced herein are trademarks of their respective companies.