

ILU - 006 series

Appearance



Material : PMMA

Application

LED Bulb(MR16,GU10,etc...)
LED Down-light , others ...

Recommended LED

CL-L400 series



Outline

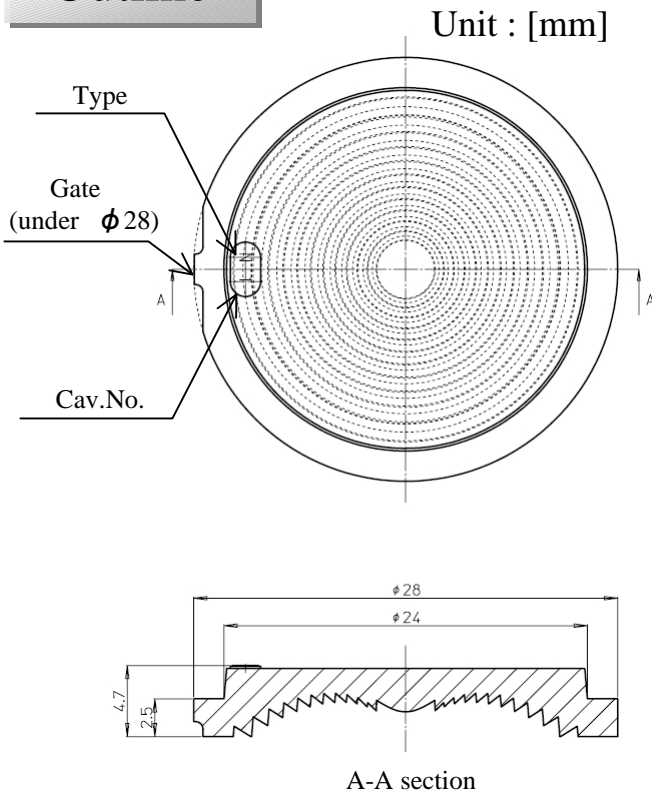

Layout

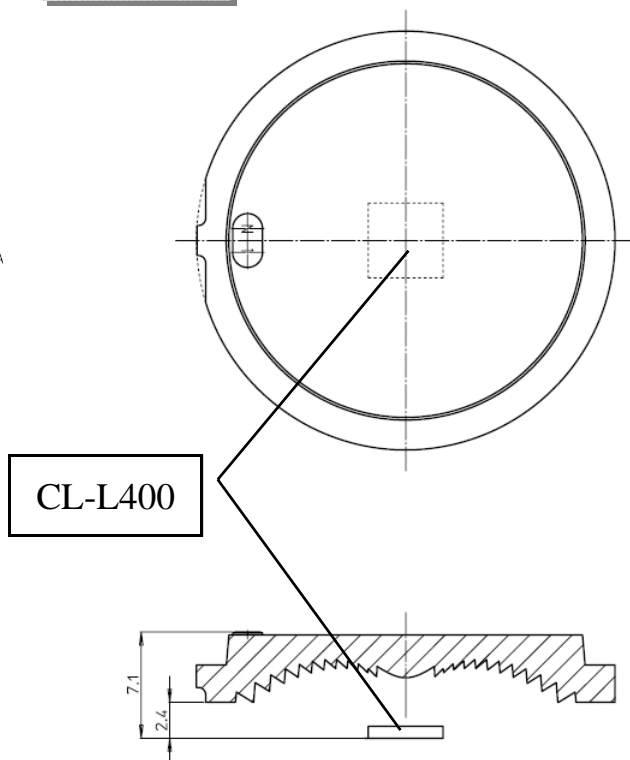

< Attention in the handling >

- To fix the lens, the use of its flange with thickness of 2.5mm is recommended.
- The lens should be placed against the LED "CL-L400" as shown in the figure above.
- The specification is subject to change without notice.
- The prism shape is not accurate.
- Do not use this product under the temperature condition exceeding 85°C.

CITIZEN ELECTRONICS CO.,LTD.

Ref.CE-P1804 02/12

ILU - 006 series

Luminous intensity

With CL-L400 Series

LED	Lens	ILU-006-N	ILU-006-M	ILU-006-W
		FWHM 19[deg]	FWHM 31[deg]	FWHM 42[deg]
CL-L400-MC1N1-A	118 [lm]	590 [cd]	280 [cd]	150 [cd]
CL-L400-MC1W1-A	115 [lm]	575 [cd]	275 [cd]	145 [cd]
CL-L400-MC1WW1-A	110 [lm]	550 [cd]	265 [cd]	140 [cd]
CL-L400-MC1L1-A	106 [lm]	530 [cd]	255 [cd]	135 [cd]
CL-L400-MC1L2-A	100 [lm]	500 [cd]	240 [cd]	125 [cd]
CL-L400-C1N-A	137 [lm]	670 [cd]	320 [cd]	170 [cd]

Directivity

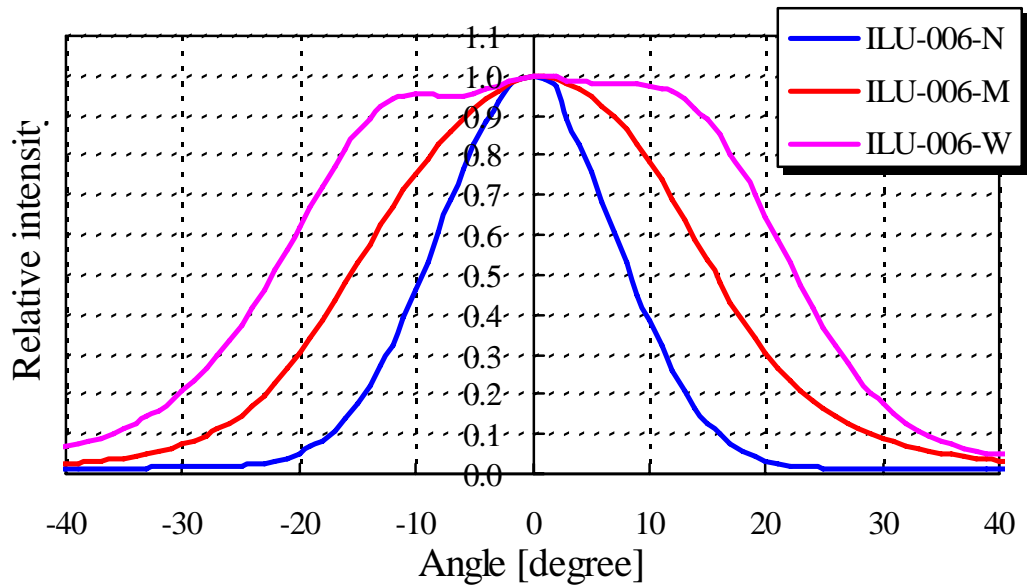

< Attention in the handling >

- To fix the lens, the use of its flange with thickness of 2.5mm is recommended.
- The lens should be placed against the LED “CL-L400” as shown in the figure above.
- The specification is subject to change without notice.
- Do not use this product under the temperature condition exceeding 85°C.

ILU - 006 series

Physical properties

Property	Test Method	Condition	Unit	Value
Optical				
Light transmission	ASTM D 1003	3.2mm	%	92
Reflectiv Index	ASTM D 542	ND@23°C	---	1.49
Mechanical				
Tensile modulus	ASTM D 638		MPa	3100
Tensile strength at yield	ASTM D 790	Max.	MPa	70
Nominal tensile strain at break	ASTM D 638	---	%	6
Flexual modulus	ASTM D 790	---	MPa	3200
Flexual strength	ASTM D 790	---	MPa	103
Charpy impact strength	ASTM D 256			7.5
Izod impact strength	ASTM D 256	Noched (23°C)	kJ/m ²	1.2
Rockwell hardness	ASTM D 785	M scale	---	93
Thermal				
Heat deflection temperature	ASTM D 648	1820kPa	°C	102
Vicat softening point	ASTM D 1525	(Rate A;1kg)	°C	111
		(Rate A;5kg)	°C	104
Melt volume flow rate	ASTM D 1238	---	g/10min	3.7
Coeffient of linear expansion	ASTM D 696	---	× 10 ⁻⁵	5.8
Electrical				
Surface resistivity	ASTM D 257	---	Ω /sq	1.00E+18
Volume resistivity	ASTM D 257	---	Ω cm	1.00E+18
Specific Inductive capacity	ASTM D 150	60cycles	---	3.7
		1,000,000cycles	---	2.2
Dielectric strength	ASTM D 149	volts/mil		500
Dielectric loss Factor	ASTM D 150	60cycles		0.19
		1,000,000cycles		0.007
Tracking resistance	ASTM D 405	---	seconds	no track
Other				
Density	ASTM D 792	---	g/cm ³	1.19
Water absorption	ASTM D 570	---	%	0.3
Flammability	UL94	---	class	HB

* Values reported are typical and should not be used for specification purpose.

< Attention in the handling >

- The data on this document is the characteristics combining ILU-006 and CLL400 series.
- ILU-006 is the lens for CLL400 series.
- Discussion will be needed separately if you combine it with LEDs other than these.
- The specification is subject to change without notice.
- Do not use this product under the temperature condition exceeding 85°C.

CITIZEN ELECTRONICS CO.,LTD.

Ref.CE-P1804 02/12