

ACL-CC-35P series LED Driver – IP67 max34W

Operating Temperature : -10 ~ +50 [°C]
 Dimension : 148 x 32 x 28 [mm]
 LED Driver : Constant Current
 Built-in: Active PFC

RoHS



Approvals / Marks :

CE IP67

Features:

Built-in active PFC function
 Constant current mode power supply - Suitable for LED lighting and moving sign applications
 Universal AC input / Fully encapsulated with IP67 (for indoor and outdoor use)
 Small and compact size | UL1310 Class II power unit, pass LPS
 Protections: Short circuit & Over current / 100% full load burn-in test

Specification:

		OUTPUT							
	Model	Current [mA]	Output Tol. [%]	Voltage [V]	Voltage Range [V]	Efficiency [%]	For LED [pcs]	Max. Power [W]	Ripple & Noise [V] p-p
	ACL-CC-35-350	350±3%	±3	80	40~80	84	12~22	28	5
	ACL-CC-35-700	700±3%	±3	48	24~48	84	8~13	34	5
	ACL-CC-35-1400	1400±3%	±3	24	9~24	84	8~13	34	200mVp-p
INPUT	Voltage	(100 ~ 240)VAC							
	Frequency	(47 ~ 63)Hz							
	Current	0.6A/100VAC 0.3A/200VAC							
	Inrush Current max.	cold start 70A/240VAC							
	Leakage current	0.5mA/240VAC							
PROTECTION	Over current	Above 105% rated output power. Protection type: Hiccup mode, recovers automatically after fault condition is removed.							
	Over Voltage	-							
	Protection class	UL1310 Class 2 power unit							
	Over temperature	Tj 140°C typically (IC1) Detect on main control IC Protection type: Hiccup mode, recovers automatically after temperature goes down.							
	No Load Operation	-							
OTHERS	Isolation Resistance	I/P-O/P:>100MΩ / 500VDC / 25 ~ 70% RH							
	Set up time	1500ms							
	Hold-up Time	50ms/200VAC							
	MTBF Qualification	30K hrs @ full load 25 °C; ambient temperature and 20k hrs @ full load 50 °C							
	AC cable / DC cable	-							
	Rise time	250ms							
	Line regulation	±1.0%							
	Burn in	100% full load burn-in test							
	PFC	Active							
	Load regulation	±2.0%							
ENVIRONMENT	Temperature	Operating: (-10 ~ +50)°C / Storage: (-40 ~ 80)°C							
	Humidity	Operating: (20 ~ +90)%RH / Storage: (10 ~ 95)%RH Non-condensing							
	Vibration	10 ~ 500Hz, 2G 10min./1cycle, period for 60min. each along X,Y, Z axes							
	Temp. Coefficient	±0.03%/°C (0~50)[°C]							
CERTIFICATION & SAFETY		Safety EN61347-1, EN61347-2-13 Immunity EN61547 Harmonic EN61000-3-2 Magnetic Emission EN55015 RoHS compliant CE mark / compliant							
SAFETY & EMC	Withstand voltage	I/P-O/P:3KVAC							
	Safety standards	Design refer to UL1310 Class 2,TUV EN60950-1, EN61347-2-13, CAN/CSA C22.2 No. 223-M91, meet IP67							
	EMS Immunity	Compliance to EN61000-4-2,3,4,5,6,8,11; ENV50204, EN55024, light industry level, criteria A							
	EMI conduction & radiation	Compliance to EN55022 (CISPR22) Class B							
	Harmonic current	EN61000-3-2,-3							
WEIGHT	1pc	N.W.: 214g G.W.: 227g							
PACKING	Box	0.35 x 0.33 x 0.25 [m]							
		100pcs / 1box							
		G.W.: 24 kg / box							

ACL-CC-35P series LED Driver – IP67 max34W

Mechanical case specification:

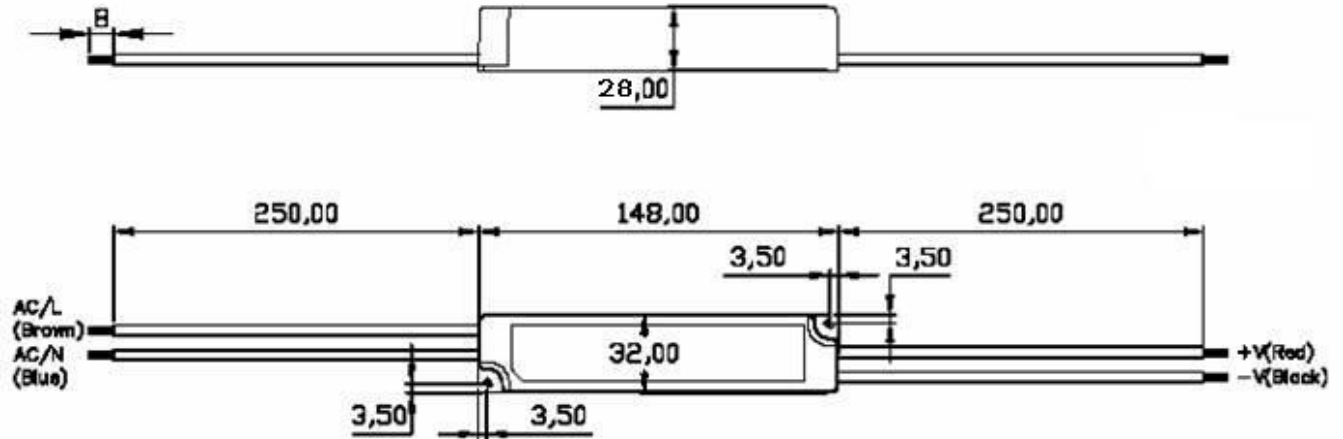

Block diagram:

